

# Installation, Operating, and Service Manual

## Badu® Stream *II*

Counter Swimming Unit



**Technical Support:**

**Address:** Speck Pumps  
8125 Bayberry Road  
Jacksonville, FL. 32256  
USA

**Hours:** (Monday - Friday) 8:00 am to 5:00 pm EST

**Toll Free:** 800-223-8538

**Phone:** 904-739-2626

**Fax:** 904-737-5261

**Website:** [www.usa.speck-pumps.com](http://www.usa.speck-pumps.com)

<b>Date of Installation:</b>	
<b>Installed by:</b>	
<b>Serial Number:</b>	
<b>For Service Call:</b>	

*Manufactured by Speck Pumps, Jacksonville Florida USA, © 2012-2013 All Rights Reserved.*

This document is subject to change without notice.

# Table of Contents

<b>1</b>	<b><i>Important Safety Instructions</i></b>	<b>4</b>
	SwimJet Combination Fitting Manufacturers Warnings . . . . .	4
	General Safety Instructions . . . . .	5
<hr/>		
<b>2</b>	<b><i>General Description</i></b>	<b>7</b>
<hr/>		
<b>3</b>	<b><i>Installation Information</i></b>	<b>7</b>
	Preparation Guide . . . . .	7
	Planning . . . . .	8
	Dimensional Drawing . . . . .	8
	Plumbing Installation . . . . .	9
	Concrete or Gunite Installation . . . . .	11
	Liner and/or Fiberglass Pool Installation . . . . .	12
	Removal of Liner . . . . .	14
	Pump and Control Box Installation . . . . .	14
<hr/>		
<b>4</b>	<b><i>Operation</i></b>	<b>14</b>
<hr/>		
<b>5</b>	<b><i>Service and Maintenance</i></b>	<b>15</b>
	Nozzle Adjustments . . . . .	15
	Winterizing . . . . .	16
<hr/>		
<b>6</b>	<b><i>Trouble Shooting</i></b>	<b>17</b>
	General Troubleshooting Problems . . . . .	17
<hr/>		
<b>7</b>	<b><i>Product Specification</i></b>	<b>18</b>
	Replacement Parts and Exploded View . . . . .	18
<hr/>		
<b>8</b>	<b><i>Limited Warranty</i></b>	<b>19</b>

## BaduStream II Certifications



Complies with UL 1563  
 CSA C22.2 No. 218.1-M89  
 Swimming Pool Equipment  
 Listing #E212148



**VGB 2008**

---

# 1 Important Safety Instructions

---

**WARNING:** Before Installing this product, read and follow all warning notices and instructions which are included. Failure to follow safety warnings and instructions can result in severe injury, death, or property damage. Call 1-800-223-8538 or visit [www.usa.speck-pumps.com](http://www.usa.speck-pumps.com) for additional copies of these instructions.

---

## Swim Jet Combination Fitting - Manufacturers Warnings

---

**Attention Installer:** This manual contains important information about installation, operation, and safe use of this product. This information should be given to the owner/or operator of this equipment.

Most states and local codes regulate the construction, installation and operation of pools and spas. It is important to comply with these codes, many which regulate the installation and use of this product.

1. **DO NOT** locate this fitting in seating areas or on the back rests for such seating areas.
2. This fitting should be vertically wall mounted only per manufacturer's instructions.
3. All fittings and fasteners should be examined for damage or tampering before each use.
4. Any missing, broken, or cracked fittings must be replaced before using this product. Only genuine Speck replacement parts may be used.
5. Acceptable fittings/pipe sizes are listed on page 9 of this manual. No other sizes are permitted.
6. Never exceed the maximum flow rate stated on this product.
7. The anti-entrapment cover must be in place when using this product. **DO NOT** use this product if the cover is missing or loose.
8. The anti-entrapment cover (part# 8) should be replaced within 10 installed years.
9. Installation requires a Phillips screw driver. Hand tighten only. **DO NOT** use electrical or air drills.
10. Consult your physician before exercising with the BaduStream or using the massage hose.
11. **DO NOT** permit children to use this product unless they are closely supervised at all times.
12. **DO NOT** remove any safety alert labels such as **DANGER**, **WARNING**, or **CAUTION**. Keep safety alert labels in good condition and replace missing or damaged labels.
13. Stay alert, watch what you are doing and use common sense. **DO NOT** use unit if you are tired and/or exhausted. **DO NOT** use unit while under the influence of drugs, alcohol, or any medications.

**CAUTION: DO NOT** increase pump size; this will increase the flow rate through the system and exceed the maximum flow rate stated on this product.

**IMPROPER INSTALLATION OR USE OF THIS PRODUCT MAY PRESENT A RISK OF HAIR OR BODY ENTRAPMENT AND DROWNING.** Install this equipment in accordance with the instructions provided.

As the manufacturer, Speck Pumps - Pool Products, Inc., hereby certifies that their Swim Jet Combination Fitting meet or exceed the requirements of the Virginia Graeme Baker Pool & Spa Safety Act, VGB 2008 and ANSI/APSP 16-2011 standards and safety regulations as set forth by the Consumer Products Safety Commission.

**“Read, and then keep these instructions for future reference”**

---

## General Safety Instructions

---

**The following guidelines provide information to minimize the risk of injury to users of pools, spas, and hot tubs.**

### **WARNING: TO REDUCE THE RISK OF ENTRAPMENT HAZARD**



*Pool and spa pumps produce high levels of suction, which can pose extreme danger if a person comes in close proximity to an open pool or spa drain or if a drain cover is loose, cracked, broken or missing. Pool and spa pumps move large volumes of water, which can pose extreme danger if a person's hair comes in close proximity to a drain that is not the proper size for the pump or pumps.*

*If not an approved single, unblockable outlet, a minimum of two functioning suction outlets per pump must be installed. Suction outlets in the same plane (i.e. floor or wall) must be installed a minimum of three (3) feet (1 meter) apart, as measured from center point to center point. Dual suction fittings shall not be located on seating areas or on the backrest for such seating areas. If any suction outlets are located closer they shall be located on two different planes (i.e. one on the bottom and one on the vertical wall, or one each on two separate vertical walls).*

**WARNING:** *Failure to keep suction outlet components clear of debris, such as leaves, dirt, hair, paper and other material can result in an increased potential for suction entrapment.*

*If not a single, unblockable outlet, in the event of one suction outlet being completely blocked, the remaining suction outlets serving the system shall have a flow rating capable of the full flow of the pump(s) or the specific suction system. If in doubt about the rating and/or head loss curve of your system, consult a qualified pool or spa professional and/or your respective equipment manufacturer(s). Also, double check with your local building/health authorities regarding single vs. multiple drain installations, etc.*

*Regularly inspect all drain covers for cracks, damage and advanced weathering. If a drain cover becomes loose, cracked, damaged, broken or is missing, close the pool or spa immediately, post a notice and keep the pool or spa closed until an appropriate VGB 2008 certified drain cover is properly installed.*

### **WATER VELOCITY AND FLOW RATES**

*The maximum water velocity through drain covers is limited by some local regulations, for example some state health departments limit the velocity through public pool drain covers to 1.5 feet per second. This velocity limit is lower than the flow rating provided by the ASME A112.19.8 certification; therefore local limit applies and must be followed. Never exceed the flow rating listed on the cover even if local code does not provide a velocity limit.*

*For additional information on proper installation refer to The Association of Pool & Spa Professionals ANSI/APSP-7 Standard and the US Consumer Product Safety Commission Guidelines for Entrapment Hazard.*

---

## General Safety Instructions - continued

---

### VGB Compliance

#### VIRGINIA GRAEME BAKER POOL AND SPA SAFETY ACT

The Virginia Graeme Baker Pool and Spa Safety Act raises certain new requirements on owners and operators of swimming pools and spas.

Pools or spas constructed on or after December 19, 2008, shall utilize:

- (A) No submerged suction outlets, a gravity drainage system with ASME/ANSI cover(s), one or more unblockable outlets; or
- (B) A multiple main drain system without isolation capability with suction outlet covers that meet ASME/ANSI A112.19.8 Suction Fittings for Use in Swimming Pools, Wading Pools, Spas, and Hot Tubs and either:
  - (i) A safety vacuum release system (SVRS) meeting ASME/ANSI A112.19.17 Manufactured Safety Vacuum Release Systems (SVRS) for Residential and Commercial Swimming Pool, Spa, Hot Tub, and Wading Pool Suction Systems and/or ASTM F2387 Standard Specification for Manufactured Safety Vacuum Release Systems (SVRS) for Swimming Pools, Spas and Hot Tubs or
  - (ii) A properly designed and tested suction-limiting vent system or
  - (iii) An automatic pump shut-off system.

Pools and spas construction prior to December 19, 2008, with a single submerged suction outlet shall use a suction outlet cover that meets ASME/ANSI A112.19.8 and either:

- (A) A multiple main drain system without isolation capability, or a single (VGB 2008 compliant) unblockable or
- (B) A safety vacuum release system (SVRS) meeting ASME/ANSI A112.19.17 and/or ASTM F2387, or
- (C) A properly designed and tested suction-limiting vent system, or
- (D) An automatic pump shut-off system, or
- (E) Disabled submerged outlets, or
- (F) Suction outlets shall be reconfigured into return inlets.

For more information about the Virginia Graeme Baker Pool and Spa Safety Act, contact the Consumer Product Safety Commission at (301) 504-7908 or visit [www.cpsc.gov](http://www.cpsc.gov).

### **WARNING - Risk of Electrical Shock or Electrocution**



*Pool pump must be installed by a licensed or certified electrician or a qualified pool serviceman in accordance with the National Electrical Code and all applicable local codes and ordinances. Improper installation will create an electric hazard which could result in death or serious injury to pool users, installers, or others due to electrical shock, and may also cause damage to property.*

***Always disconnect power to the pool pump at the circuit breaker before servicing the pump. Failure to do so could result in death or serious injury to serviceman, pool users, or others due to electric shock.***

---

# 2 General Description

---

## Badu®Stream II

The Badu SwimJet Systems from Speck Pumps are designed to be installed during the construction of your pool to create a water treadmill for anyone wanting a therapeutic and effective exercise.

The Badu SwimJet Systems can be installed in any type of pool, large or small, from gunite to vinyl liner. It has no protruding parts ensuring pool user's safety, is very compact and installs at minimal cost. The self-contained, flush-mounted unit is a jet-propulsion system that pumps water into the pool creating a current in excess of 5,700 gallons per minute from a single recessed jet housing.

Topping off the experience is the pulsating massage hose which can be attached to the jet nozzles for easy and convenient massage treatments for joints and muscles. *(NOTE: The massage hose is sold separately.)*

---

# 3 Installation Information

---

## Preparation Guide

---

1. Upon receipt of the swimjet system, check the cartons for damage. Open each carton and check the pump(s) (F), jet housing(s) (A), and control box (E) for concealed damage, such as cracks, dents, or a bent base. If damage is found, contact the shipper or distributor where the swimjet was purchased.

2. Inspect the contents of each carton and verify that all parts are included. All parts are manufactured of corrosion-resistant material and combined in one single housing (two or three single housings for multi-jet systems) which can be installed in pools of any size and shape. *(See Figure 1)*

A. Flush mounted Jet Housing

B. Square, Anti-Entrapment Cover (8<sup>1</sup>/<sub>4</sub>" x 8<sup>1</sup>/<sub>4</sub>" ) undetectable pump suction. *(Optional Round Cover available)*

C. Adjustable Water Flow Jet Nozzle

D. Air Regulator adjusts amount of air bubbles in water flow.

E. Control Box with GFCI pneumatic button and tubing.

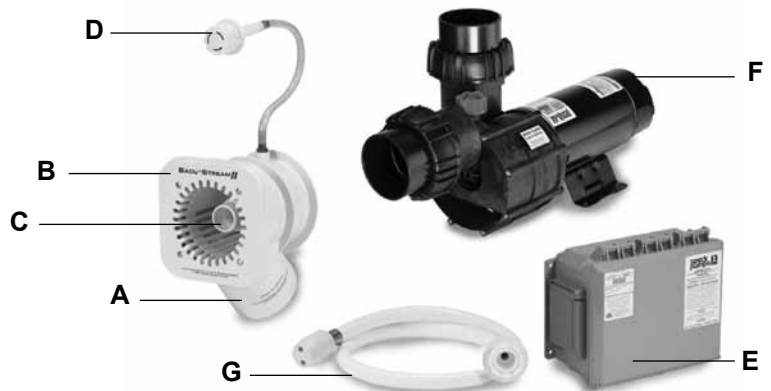

Figure 1

F. Speck 4 HP or 3.5 HP self-priming, plastic pump, single phase with thermal overload *(no motor starter required)*. Optional three phase motor and control box available. *(NOTE: Normal priming pump available for installation below water level.)*

G. Massage Hose with pulsator may be attached to jet nozzle. *(NOTE: The massage hose is sold separately.)*

## Planning

The BaduStream is normally incorporated into the original pool design. However, it can be added to any pool at a later date. *(NOTE: This fitting should be vertically wall mounted only per these instructions. Failure to follow safety warnings and instructions can result in severe injury, death, or property damage.)*

The BaduStream can be installed in any size pool. We suggest a minimum pool size of 7 ft. wide, 14 ft. long and 3½ ft. deep in order to swim. Most swimmers prefer 16 ft. in length or longer. The extra length allows the swimmer to comfortably drift back and swim up stream. The BaduStream is complete with a jet housing, 4 HP or 3.5 HP pump, control box, and optional massage hose. The only additional requirement is the plumbing. (4" pipe for 4 HP and 3" pipe for 3.5 HP units.) Consult local codes for minimum distance between pump and pool. Locate pump as close to the BaduStream as practical.

**WARNING: DO NOT** locate the jet housing in seating areas or on the back rests for such seating areas.

Use at least 4" pipe when distance between jet housing and pump is 30 ft. or less and 6" for pipe runs longer than 30 ft.

**CAUTION:** Acceptable fittings/pipe sizes are listed on page 9 of this manual.

The 4 HP, self-priming, plastic pump has a single phase motor with thermal overload (no motor starter required). The 4 HP single phase motor draws a maximum of 19.4 amps @ 230V. The unit requires a minimum circuit of 30 amps. Install a 40 amp breaker to avoid nuisance tripping when pump is turned on and off frequently. The starting current of the 4 HP motor can reach up to 6 times the running currents. (Three phase motor draws a maximum of 12.8 amps @ 230V and 6.4 amps @ 460V.) The 3.5 HP single phase motor draws 13.6 amps @ 230V.

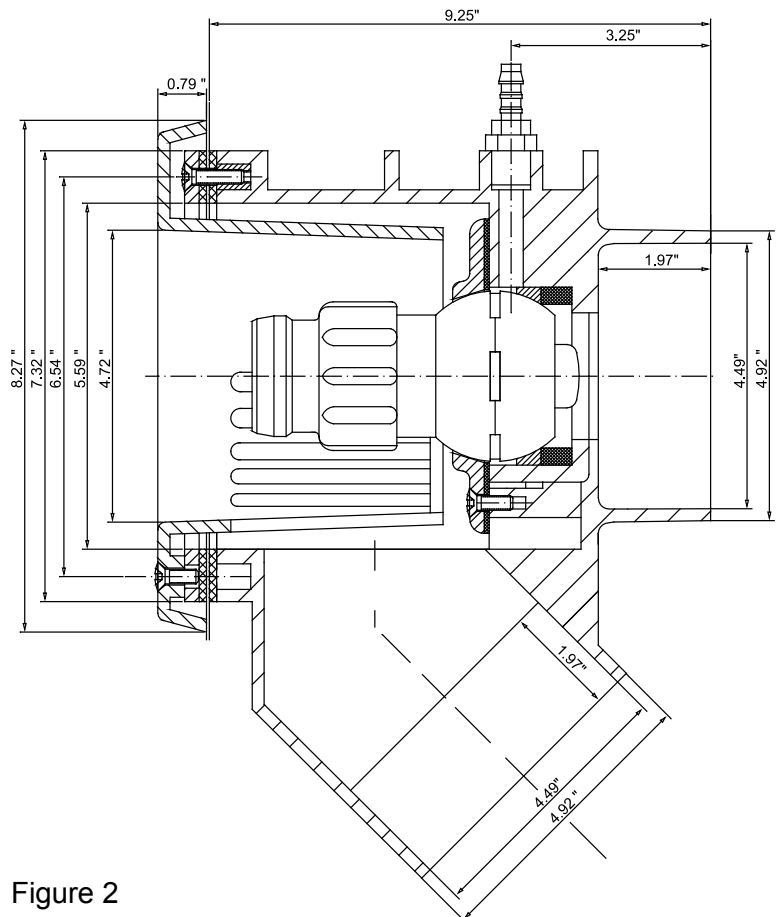
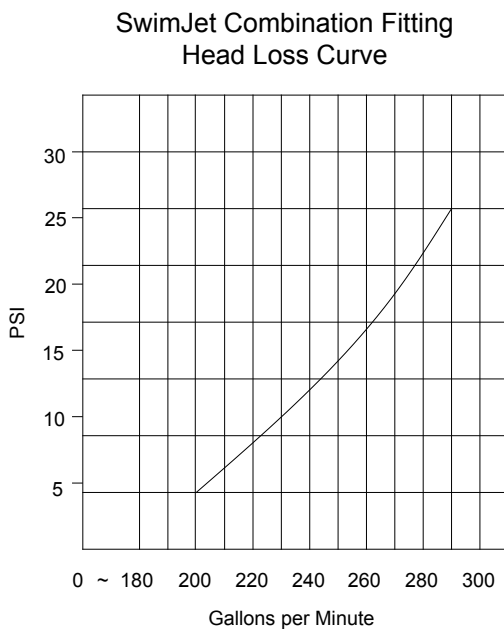

Figure 2  
BaduStream dimensional drawing



## Plumbing

The BaduStream assembly package contains all necessary parts for the installation of the unit into concrete, gunite, liner or fiberglass pools.

PLUMBING REQUIREMENTS					
BADUSTREAM II	Pump	Distance	Pipe Size	Approx. flow	Pressure
Three Jets	(2) 4 HP	10 to 30 ft.	4"	651 GPM	16 PSI
		up to 50 ft.*	6"	651 GPM	16 PSI
Two Jets	4 HP	10 to 30 ft.	4"	380 GPM	14 PSI
		up to 50 ft.*	6"	400 GPM	14 PSI
One Jet	4 HP	10 to 30 ft.	4"	217 GPM	18 PSI
		up to 50 ft.*	4"	217 GPM	18 PSI
One Jet	3 HP	10 to 30 ft.	3"	200 GPM	12 PSI
		up to 50 ft.*	4"	200 GPM	12 PSI

\* 6" pipe will allow distances of well over 50 ft. However, control box needs to be within 50 ft. for the pneumatic on/off button to function properly.

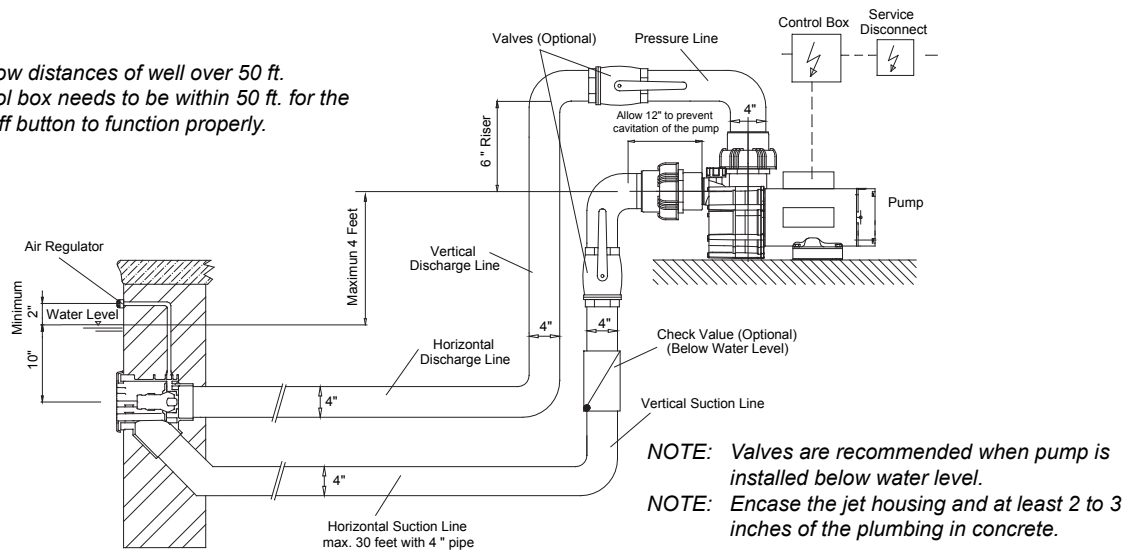

Figure 3

**CAUTION:** All necessary screws and bolts included with the BaduStream are stainless steel. ALL screw threads and threaded inserts are METRIC! ONLY METRIC bolts and nuts may be used! The two exceptions are the intake and delivery connections on the BaduStream and pump housing and the hardware for the air regulator assembly. The intake and delivery connections on the pump model 21-80 are 4" Slip (3" Slip on pumps Model 72). The air regulator assembly hardware is US standard thread.

**CAUTION:** The center of the housing (the nozzle) should be 10" BELOW water level for maximum efficiency. The air regulator should be approximately 4" (or minimum 2") ABOVE the water level. (See Figure 3)

**CAUTION:** When connecting the pressure line into the pressure connection on top of the 4 HP pump Model 21-80, first install a 6" (15 cm) riser (See Figure 3) before installing an elbow and leading the pressure line downward to the pressure connection at the jet housing. This will guarantee trouble-free priming of the pump. (Not required for the 3.5 HP Model 72)

**CAUTION:** When using 6" pipe the suction line should run to a point directly under the pump and up to the water line in 6" and finish vertical and elbow into the pump in 4" to minimize priming time. (See Figure 3)

**CAUTION:** In areas with soft soil conditions or with frequent earth movement, a flexible section of hose should be attached to the back of the jet housing to prevent housing breakage.

**CAUTION:** Throughout the entire installation, make sure the plumbing connected to the BaduStream housing is well supported. Unsupported plumbing will crack the housing.

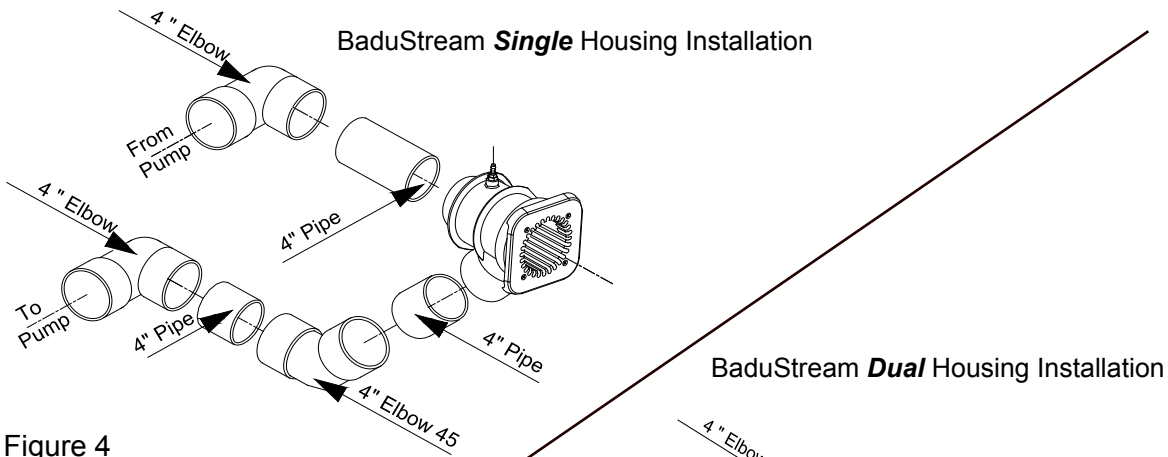

Figure 4

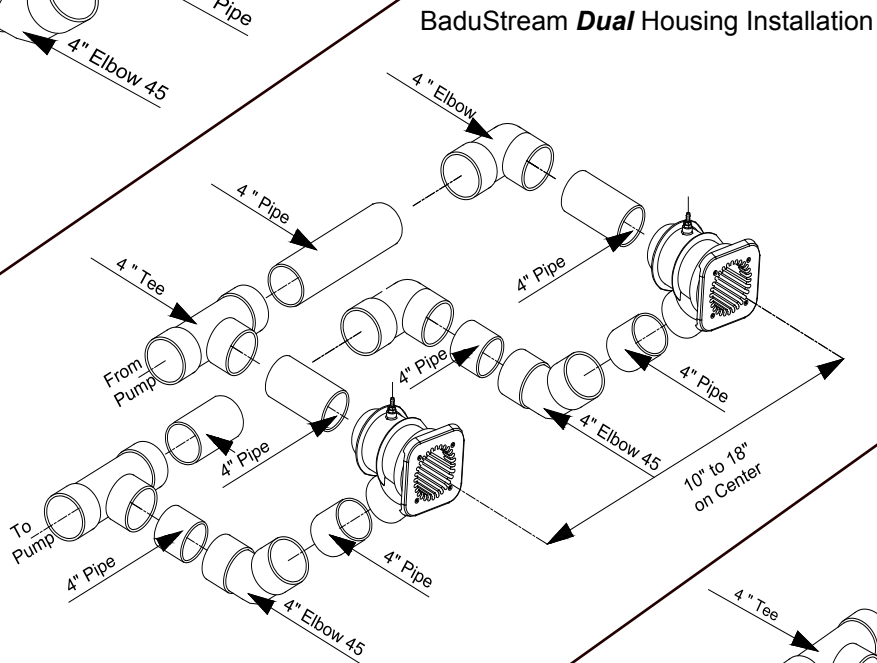

Figure 5

**NOTE:** (For *Dual* and *Triple* Jet Installation) Increase the pipe size to 6" when jets are more than 30 ft. from the pump. Use 6" x 4" bushings after 4" manifold tees.

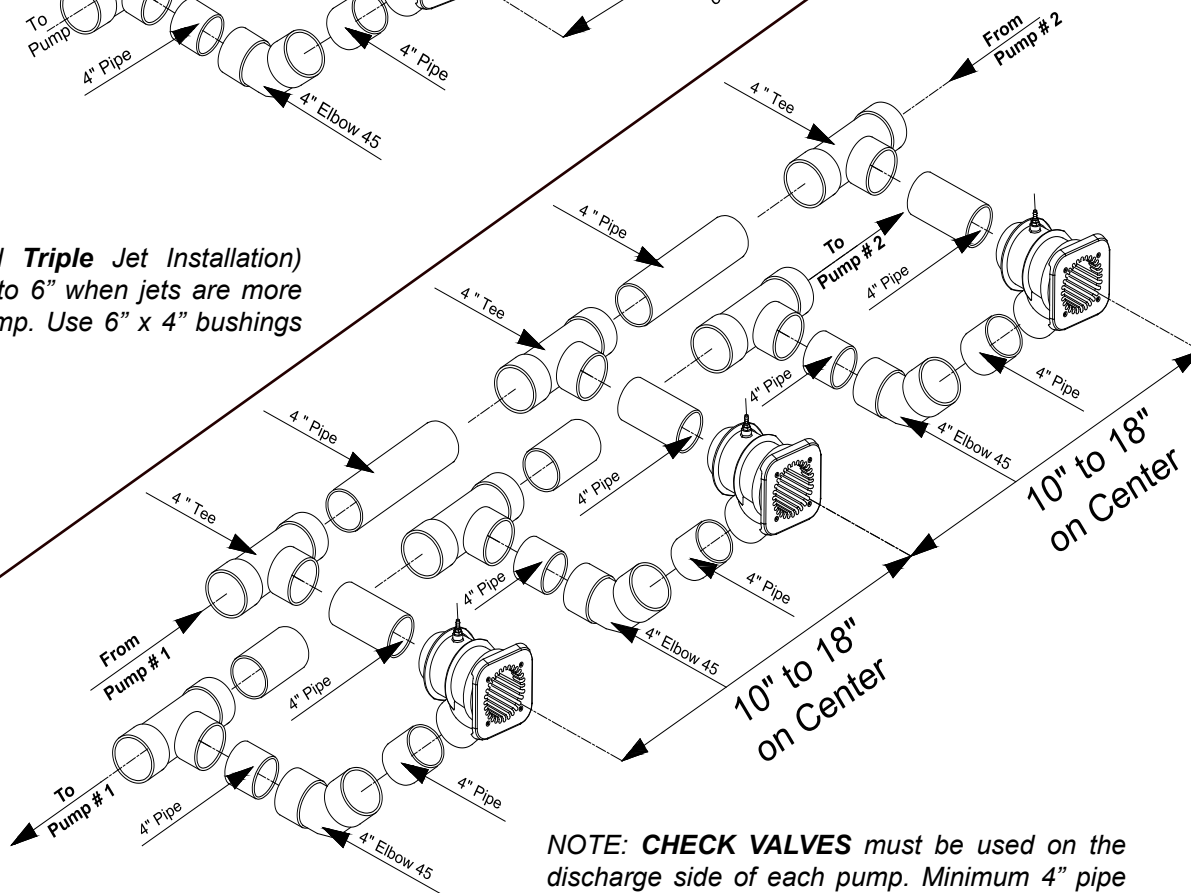

Figure 6  
BaduStream *Triple* Housing Installation

**NOTE:** **CHECK VALVES** must be used on the discharge side of each pump. Minimum 4" pipe between pump and BaduStream plumbing manifold.

---

## Concrete or Gunite Installation

---

### 1. Pre-plumb BaduStream housings:

- A. Install plumbing manifold or approximately 12" of 4" SCH 40 pipe to both suction and discharge fittings on the jet(s) housing. *NOTE: If plumbing exceeds 30 ft. between the jet housing and pump, increase pipe size to 6". Install a 6" x 4" reducing bushing as close to jet housing as possible.*
- B. Install air control PVC hose to hose socket insert fittings (*part #6*). Use hose clamps to secure hose to insert fittings.

### 2. Tape the jet housing to keep concrete out of threaded inserts and out of the inside of the housing.

### 3. Place the jet housing into reinforced steel. *Jet housing location is very important.*

- A. Locate air control hose connector (*part #6*) at the top and center of jet housing. Air control hose connectors must be vertical or the square cover will be uneven in appearance.
- B. The center of the housing (*the nozzle*) should be 10" **BELOW** water level for maximum efficiency.
- C. Front edge of jet housing should finish even with inside gunite wall. Make sure a V shaped groove is scraped out around the housing approximately 1 1/2" deep to allow marcite to seal against the housing. **DO NOT** disassemble jet nozzle from housing.
- D. Recheck location of the jet housing when gunite is being applied. The force of the gunite may move the jet location.
- E. To avoid stress on the jet housing, we recommend that the BaduStream housing be encased with gunite and at least 2 to 3 inches of the plumbing stub out is covered with gunite.

**NOTE: Stress on the plumbing may crack the BaduStream housing.**

### 4. Air regulator installation should be approximately 4" (*or minimum 2"*) **ABOVE** the water level.

- A. Air regulator holder and hose socket insert fitting connect to PVC hose. Make sure the air regulator holder face is tapped over to prevent gunite from entering holder.
- B. Air regulator can be located in the tile line above water line or in the deck. When tiling the pool, adjust the air regulator holder to proper positioning 4" (*or minimum 2"*) **ABOVE** the water level. Place and set with hydraulic cement. Install air regulator flush with the inside pool wall. Drill a 1/2" hole in the tile even with the center hole on the air regulator. Then tile over the air regulator holder (*part#17*). *Note: Be sure NOT to plug the center hole of the air regulator holder with thinset or the tile.*

### C. Install the air regulator sub-assembly.

- |                                     |          |
|-------------------------------------|----------|
| 1. Top Part                         | Part# 22 |
| 2. Bottom Part                      | Part# 23 |
| 3. Screw M10 x 80                   | Part# 24 |
| 4. Hose Ring - 16 x 30 x 80         | Part# 25 |
| 5. Gasket - Air Control 42 x 11 x 2 | Part# 26 |

- D. To install the bottom parts of the sub assembly, a flat head screw driver is required to tighten the screw to the holder.

*(Make sure the air regulator holder is free of debris or the screw (part #24) will not screw in properly.)*

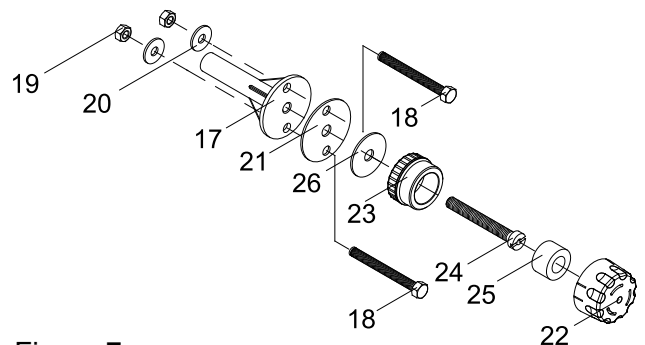

Figure 7  
Air Regulator Assembly

---

## Concrete or Gunite Installation - continued

---

*Note: Make sure the gasket (part #26) is on the back side of the bottom part (part #23) against the tile. This will keep the parts secure to the tile.)*

E. Install the top part (part #22). Snap the top part to the bottom part (part #23) and turn clock wise until you hear it ratchet. Turn clock wise to adjust the air.

5. When installing the BaduStream Cover (part #8). Use a Phillips head screw driver and tighten to 1.5 Nm or hand tight. **DO NOT** use electrical or air drills.

6. Keep all parts not being used now in original box. Store in a safe place until needed.

An extension ring is available (*upon request*) for an application that has special needs.

6. The following is a list of all parts that **ARE NOT USED IN A GUNITE INSTALLATION:**

1. Gasket - Clamping Ring	Part# 12
2. Bolt - 1/4-20 x 1-1/2"	Part# 18
3. Nut - 1/4-20	Part# 19
4. Washer 1/4"	Part# 20
5. Gasket 60 x 11 x 2	Part# 21
6. Screw - Jet Housing 14 X 1"	Part# 27

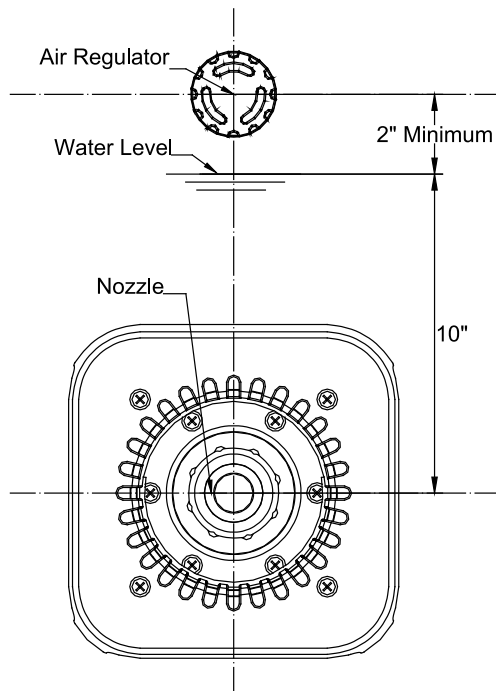

Figure 8  
Template for Installation in Gunite or Concrete Pools.

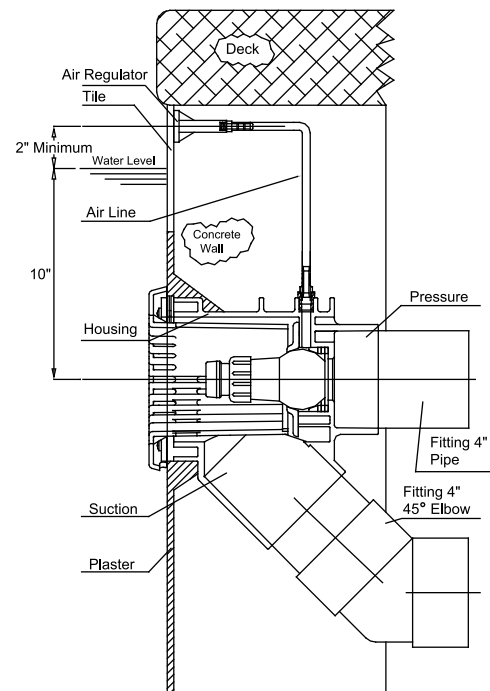

Figure 9  
BaduStream in Concrete or Gunite Pool.

---

## Liner and/or Fiberglass Pool Installation

---

1. Using the clamping ring (part #3) as a template, drill holes in the pool wall for installation. The center line of the clamping ring should be 10" below the surface of the water. (See Figure 8) Two additional holes will need to be drilled at the 3 and 9 o'clock positions for installation of the housing (part #7). The four brass inserts in the clamping ring should be at the 2, 4, 8 and 10 o'clock positions.

## Liner and/or Fiberglass Pool Installation - continued

2. Mount the housing (*part #7*) and one gasket (*part #12*) on the outside of the pool wall using two (2) screws 14 x 1" (*part #27*). Install the screws from the inside of the pool wall through the holes drilled at 3 and 9 o'clock positions. (See *Figure 10 & 11*)

3. Install the clamping ring (*part #3*) and the gasket (*part #12*) on the inside of the pool wall using eight (8) screws (*part # 9/2, 9/3, 9/4, or 9/5*) Screw lengths vary depending on the installation.

A. A good RTV silicone may be used with the gasket when mounting the jet housing, but in most cases is not necessary. Installer should decided whether or not the silicone is necessary.

B. When installed properly, the center of the housing (*part #7*) will be 10" below the surface of the water and the hose connector 1/4" (*part #6*) will be at the top center of the jet housing.

C. When installing the BaduStream Cover (*part #8*). Use a Phillips head screw driver and tighten to 1.5 Nm or hand tight. **DO NOT** use electrical or air drills. (*NOTE: The square cover, part #8, will have an uneven appearance if the housing is not installed properly.*)

4. For the air regulator assembly, one 1/2" hole must be provided, preferably along the vertical axis, approximately 4" (*or minimum 2"*) **ABOVE** the water line. (See *Figure 10 & 11*). Using the air regulator assembly gasket (*part #21*), mark and drill two 1/4" mounting holes. (See *Figure 10*) Use two flat head 1/4 - 20 machines screws (*part #18*) and two 1/4-20 nuts (*part #19*) to mount the air regulator. (*NOTE: The flat head on the inside of the pool wall and the nut on the outside of the pool wall.*)

5. Keep all parts not being used now in original box. Store in a safe place until needed.

**For Liner Pools Only:** Install the jet housing and air regulator prior to installation or replacement of the pool liner.

**For Steel Walled Pools:** An optional butterfly gasket (*part #12A*) maybe purchased to replace the two (2) gaskets (*part #12*). Increase the jet housing hole from 5.59" to 5.75" for installation. (See *Figure 10*)

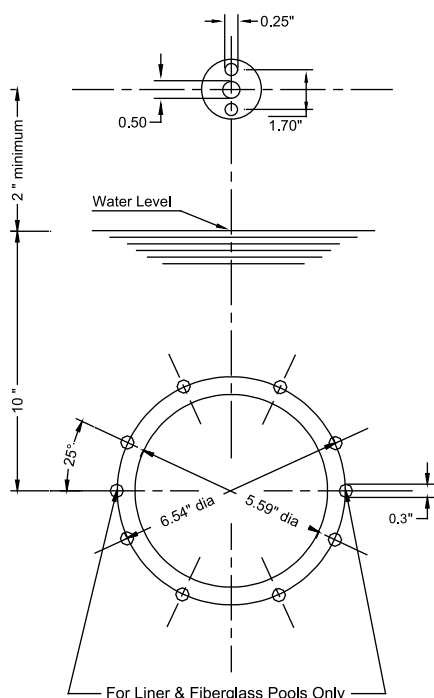

Figure 10  
Cutout Pool Wall for BaduStream housing.

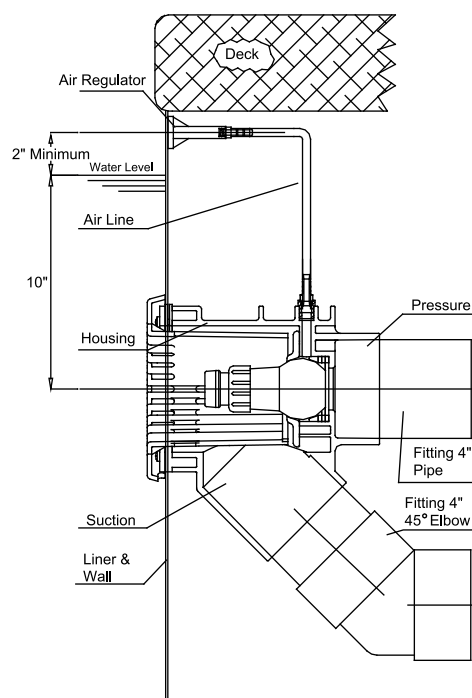

Figure 11  
BaduStream in Liner or Fiberglass Pool.

---

## Removal of Liner

---

When replacing liner or removing liner for repairs; remove 4 screws (*part #9/1*) which hold the square cover (*part #8*) to the jet housing. Remove all screws (*part #9/2 & 9/3*) except the top two, which hold the clamping ring (*part #3*) and gasket (*part #12*) to the jet housing. Back out the two remaining screws approximately halfway and check for any movement of the jet housing from the wall. (*NOTE: If the two counter sunk screws (part #27) which hold the jet housing to the wall were installed, the jet housing should not move, and the two remaining screws can be removed.*) Remove one of the remaining two screws and slide the clamping ring (*part #3*) to the side. Replace all the screws before removing the last screw. Remove or replace the liner. Reverse the process to install liner.

*NOTE: When replacing the clamping ring and screws: locate screw heads under liner, make a small cut on the liner at the screw heads and push the liner over the screw head.*

---

## Pump and Control Box Installation

---

**CAUTION:** Before installing the Speck Pump, read the entire pump owner's manual found in the pump box.

Consult local codes for minimum distance between pump and pool. Locate pump as close to the pool as practical.

The air button works up to a maximum of 50 ft. There is 50 ft. of air tubing in the BaduStream box.

**WARNING:** To reduce the risk of injury, do not permit children to use this product unless they are closely supervised at all times.

The wiring of the pool motor and control box should be done by a licensed electrician in accordance with local codes. Be certain that the motor frame and control box are grounded. Motor name plate has voltage, phase, amp draw, and other motor information as well as wiring connection instructions.

**BONDING:** As required by National Electrical Code Article 680-22, the pump motor must be electrically bonded to the pool structure (reinforced bars, etc.) by a solid copper conductor not smaller than No. 8 AWG via the external copper bonding lug on the pump motor.

**GROUNDING:** Permanently ground the pump motor and control box using a conductor of appropriate size. Connect to the No. 10 green headed ground screw provided inside the motor terminal box.

**NOTE:** Do not connect to electric power supply until the unit is permanently grounded.

**Section 8** concerns the electric motor and control box only since all other parts, the pump, the jet unit, etc. have complete and absolute separation from the pool water.

---

# 4 Operation

---

## Operation

---

Before starting the pump for the first time, remove the red filler plug or strainer tank lid. Fill the pump body with water until the water is level with the suction inlet. Replace the red filler plug or lid, hand tighten, making sure the o-ring is not damaged. Due to the large volume of air that can be present in the vertical portion of the suction above the waterline, initial priming time may be longer than with regular pool filtration pumps. It may take up to ten (10) minutes. This will not damage the mechanical seal. If prime is not achieved in ten (10) minutes, stop the pump, re-fill the pump body and restart.

---

## Operation - continued

---

**WARNING: Do not use or operate the BaduStream if the anti-entrapment cover is missing, broken, or loose.**

To start swimming, jogging or running it is suggested that the two nozzles are pointed slightly inward and slightly upward so that the water “breaks” approximately 4 ft. in front of the BaduStream. (See *Section 5 Nozzle Adjustment to properly adjust the nozzles.*) Start swimming with only minimal force in arms and legs until you feel yourself drifting backwards, then add force and swim upstream until a proper balance is found between force and endurance.

Keep in mind that this unit is designed for a balanced workout. Find a pace that you can keep up for at least 20 minutes. Out pacing is always possible. The idea is to continue exercising for an extended period of time.

**Consult your physician before attempting any strenuous exercise. This product may not be challenging or satisfying for all levels of exercise.**

The air regulator permits a controlled mixture of air into the water flow and creates a unique, invigorating, bubble bath effect. It will also add additional resistance to swim against.

The BaduStream’s adjustable flow nozzle(s) enables the swimmer to regulate the volume of water released through the jet(s). Turning the nozzle clockwise reduces the flow. The swivel nozzle(s) of the BaduStream can be positioned in various directions, allowing swimmers to use various swim styles.

**Optional Accessory:** The Badu Swim Mirror is a perfect addition to the BaduStream, this portable mirror is designed to be the perfect tool to help swimmers stay in the “swim lane”.

**Optional Accessory:** A pulsating massage hose can be attached to one of the nozzles to enjoy a massage as advised by your physician. (See *Figure 1 Letter G*)

**Directions for use:** Consult your physician before using the massage hose. To reduce the risk of injury, do not permit children to use the massage hose with pulsator unless they are closely supervised at all times. Close the air regulator. Reduce the volume of water by turning the adjustable flow nozzle(s) clockwise.

Under certain conditions it is possible that the current “drifts off” to the left or to the right from the middle due to water bouncing off the back wall. In the event that this interferes with your swimming action, turn unit off for a few minutes and restart.



Figure 12  
Badu Swim Mirror

---

# 5 Service and Maintenance

---

## Nozzle Adjustment

---

When setting the nozzles for basic swimming, it is recommended that you set the nozzles in such a way that each nozzle(s) intersects 4 feet away while at the same time breaks the surface.

---

## Nozzle Adjustment - continued

---

To help set the nozzles in a neutral position, please follow these instructions:

1. Parts required:
  - Quantity 2 - 4'x1 1/2" PVC Pipe
  - Quantity 2 - 1 1/2" MPT x 1 1/2"/1 1/4" Hose Adaptor
  - Quantity 2 - Female Adapter 1 1/2" Slip x 1 1/2" FPT
2. Turn off the jet pump(s)
3. Insert each jet adjustment tool into jet nozzle.
4. Move each jet adjustment tool toward each other until each pipe touches at water level.
5. Remove jet adjustment tool.

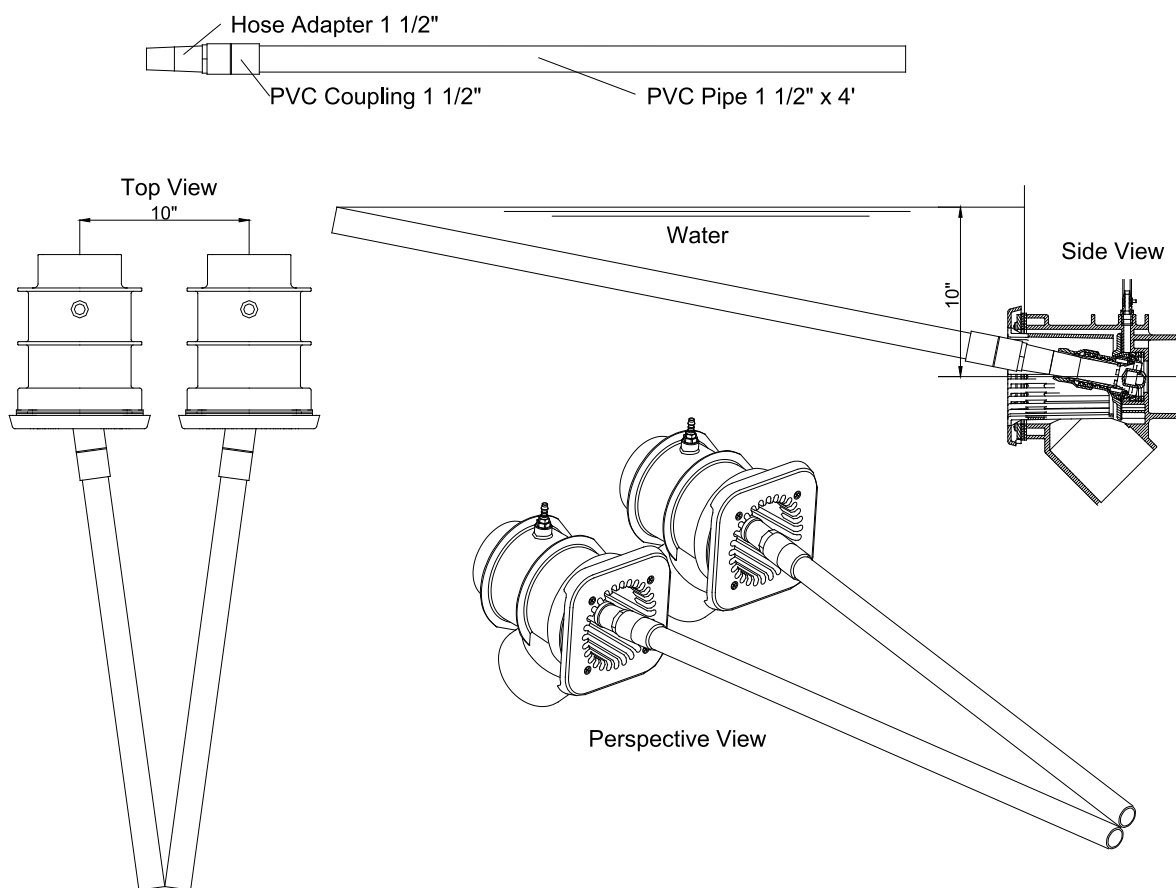

Figure 13  
BaduStream Nozzle Adjustment

---

## Winterizing

---

In areas subject to freezing water temperatures, you should protect your equipment. We recommend you purchase a winter cover kit part #2308752006K. This kit includes one (1) winter plate, one (1) gasket and four (4) screws.

Also, you can protect your swimjet system as follows: Drain pool until water level has dropped below the anti-entrapment cover. Then protect pump by removing drain plug and red filler plug (or lid).



---

# 6 Troubleshooting

---

---

## Frequently Asked Questions

---

### **How is the current generated?**

The pump generates up to 400 GPM coming out of two (2) jet nozzles at 27 ft. per second and 36 ft. per second thru one (1) nozzle creating a swim current in excess of 5700 GPM, measured 6 ft. from the jet.

### **What size pool do I need?**

The BaduStream can be installed in any size pool. However, we recommend a minimum length of 14' and a minimum width of a 7 ft. swimming lane.

### **What size plumbing is necessary? How far away from the BaduStream can the pump be installed?**

Use 4" plumbing up to 30'. For runs longer than 30' use 6" plumbing. The pump can be placed as close to the BaduStream as local codes will allow.

### **How many amps does the pump operate at?**

4.0 HP: Maximum 19.4 amps @ 230 V

3.5 HP: Maximum 13.6 amps @ 230 V

### **What size breaker do I need?**

You must use a 40 amp breaker for the 4 HP pump or 30 amp breaker for the 3 HP pump to avoid nuisance tripping.

### **Is the BaduStream approved?**

Yes. The BaduStream swim jet system is listed by MET and complies with UL standard 1563 Swimming Pool Equipment, ASME standard *ANSI/ASME A112.19.8 (ANSI/APSP-16, 2011)* Standard for Swim Jet Combination Fittings, and is VGB 2008 compliant.

### **Do the covers come in different colors?**

Yes. The round covers can be ordered in gray or black. The square cover is only available in black or white.

### **Does the air regulator come in different colors?**

Yes. The air regulator can be ordered in black.

### **Does it matter if the housing is installed higher or lower than the manual states?**

Yes, the center of the jet must be 10" **BELOW** estimated water level for proper performance of unit.

### **Can the air regulator be placed elsewhere?**

Yes, as long as it is not continuously flooded with water.

### **Can the pump be placed below water level?**

Yes. However, for best performance we recommend ordering pump for flooded suction (Model 21-80/33G) instead of self-priming (Model 21-80/33GS). We recommend installing valves for ease of maintenance.

### **How far away can the air button function properly?**

A maximum of 50 ft. Consult factory for distances over 50 ft.

### **Do I need to install a motor starter?**

No. The pump has a built-in thermal overload.

### **Should this be tied into my filter system?**

No. The swim jet system and the filter system should not be plumbed together as they each provide very specific functions.

### **Can I use with automated controls?**

Yes. It comes with the ability to tie into automated control systems or other switching devices.

# 7 Product Specification

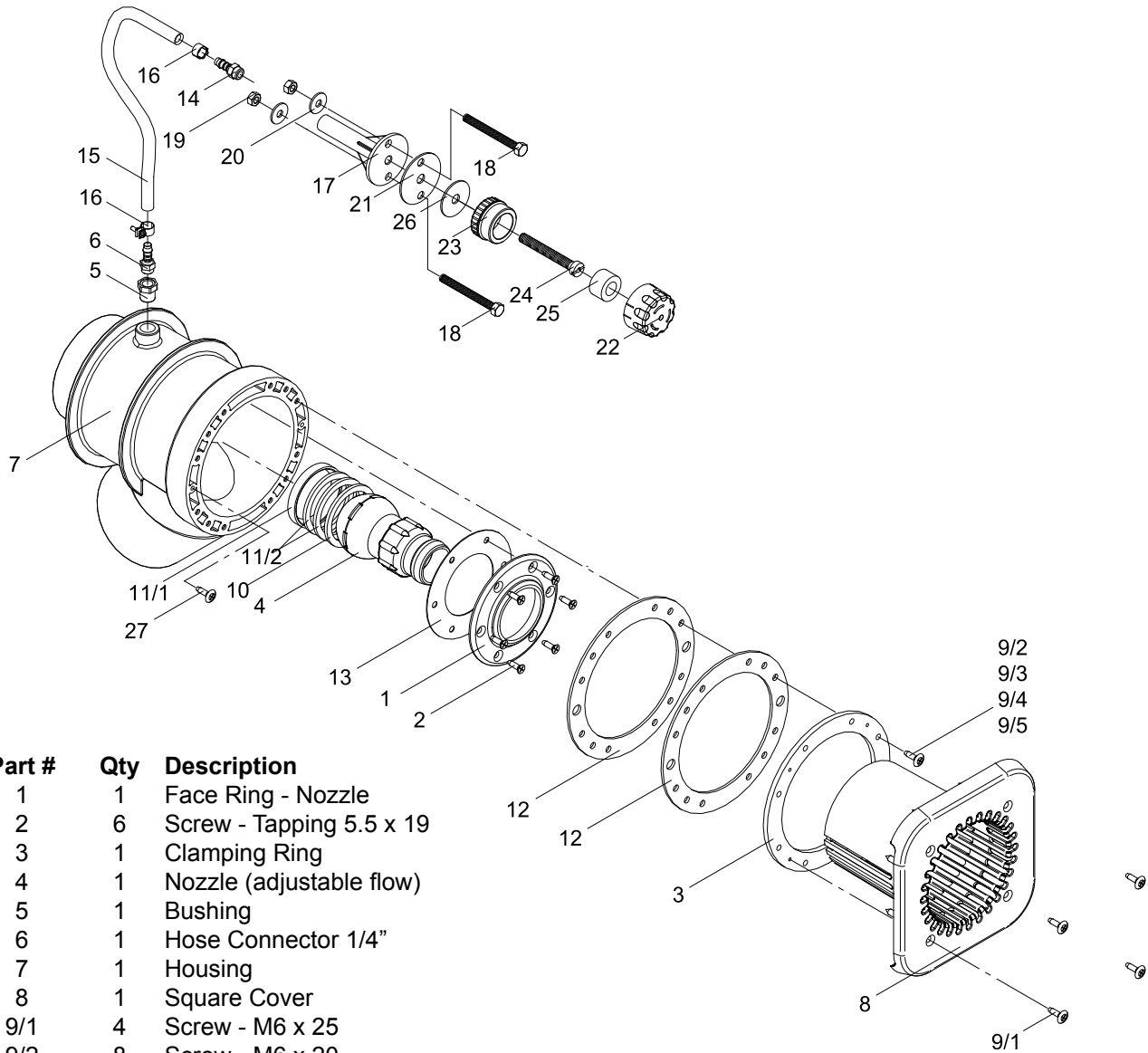

Part #	Qty	Description
1	1	Face Ring - Nozzle
2	6	Screw - Tapping 5.5 x 19
3	1	Clamping Ring
4	1	Nozzle (adjustable flow)
5	1	Bushing
6	1	Hose Connector 1/4"
7	1	Housing
8	1	Square Cover
9/1	4	Screw - M6 x 25
9/2	8	Screw - M6 x 20
9/3	8	Screw - M6 x 25
9/4	8	Screw - M6 x 40
9/5	4	Screw - M6 x 45
10	1	Seat - Nozzle
11/1	1	Spacer Ring - 6.2
11/2	2	Spacer Ring - 4
12	2	Gasket - Clamping Ring
12A	1	Gasket - Butterfly (not shown)
13	1	Gasket - Face Ring
(14 - 21)	1	Holder w/ Hose Subassembly
14	1	Hose Fitting - 1/4"
15	1	Hose - 8 x 3
16	2	Hose Clamp 14/9
17	1	Holder - Air Regulator
18	2	Screw - 1/4-20 x 1-1/2"
19	2	Nut - 1/4-20
20	2	Washer - 1/4"
21	1	Gasket 60 x 11 x 2

Part #	Qty	Description
(22-26)	1	Subassembly Complete
22	1	Top Part - Air Regulator
23	1	Bottom Part - Air Regulator
24	1	Screw - Air Regulator M10 x 80
25	1	Hose Ring - Air Regulator 16 x 30 x 80
26	1	Gasket - Air Control 42 x 11 x 2
27	2	Screw - Jet Housing 14 x 1"
	*1	Extension Ring (pre-glued) (not shown)

### Optional Winter Cover Kit:

Part #	Qty	Description
12	1	Gasket - Clamping Ring
9/1	4	Screw - M6 x 25
	1	Winter Plate (not shown)

\* Extension Ring

An extension ring (not shown) is available upon request.

# 8 Limited Warranty

Speck Pumps-Pool Products, Inc. grants solely to the original consumer purchaser (“Buyer”) of the Badu® SwimJet System(s) the following personal, non-transferable and limited warranty on the following terms and conditions (the “Limited Warranty”): the Badu SwimJet System(s) is warranted to be free of material defects in materials or workmanship under normal use for a period of one (1) year beginning on the date of the Buyer’s purchase of the Badu SwimJet System(s) (the “Limited Warranty Period”). Notwithstanding any provisions herein to the contrary, the warranties and obligations hereunder shall not in any event extend for more than two (2) years beyond the date of shipment of the Badu SwimJet System(s) from the factory (the “Limited Warranty Period”). The Limited Warranty is subject to each of the following additional terms and conditions:

**1. IN THE EVENT OF ANY BREACH OF THE LIMITED WARRANTY, SPECK PUMPS-POOL PRODUCTS, INC.’S ENTIRE OBLIGATION AND LIABILITY TO BUYER, AND BUYER’S SOLE AND EXCLUSIVE REMEDY SHALL BE AS FOLLOWS:**

Speck Pumps-Pool Products, Inc. will, at its option, either repair or replace the Badu SwimJet System(s) or refund to Buyer the purchase price actually paid by Buyer for the Badu SwimJet System(s) subject to the Limited Warranty. Speck Pumps-Pool Products, Inc. shall have no obligations under the Limited Warranty unless Buyer delivers timely written notice to Speck Pumps-Pool Products, Inc. of the Limited Warranty claim within the Limited Warranty Period and returns the Badu SwimJet System(s) to Speck Pumps-Pool Products, Inc. if requested. To the fullest extent permitted by law, Speck Pumps-Pool Products, Inc. expressly disclaims any liability for, and the Limited Warranty does not include or cover, any labor, costs or other expenses in connection with the removal, transportation, shipment, insurance, replacement, repair, or installation of repaired or replaced parts or for any other costs or expenses or damages to property or things including, but not limited to, those arising in connection with the use of, or inability to use, the Badu SwimJet System(s).

2. To the fullest extent permitted by law, the Limited Warranty will be void and of no force or effect and Speck Pumps-Pool Products, Inc. will have no liability, responsibilities or obligations to Buyer or with respect to the Badu SwimJet System(s) in the event of the occurrence of any one or more of the following:

- (a) Any damage to the Badu SwimJet System(s) caused by Buyer, any third party, ground movement, other natural forces, acts of God or any other sources or causes not arising from a breach of the Limited Warranty, excluding ordinary wear and tear;
- (b) Any replacement, modification, alteration or repair of any parts or components of the Badu SwimJet System(s) by anyone other than Speck Pumps-Pool Products, Inc.;
- (c) Any abuse, misuse, accident, tampering with, improper installation or modification of the Badu SwimJet System(s) or any other actions, inactions or failures to act that violate the terms and conditions of this Limited Warranty;
- (d) Buyer’s failure or inability to present an invoice, bill, receipt or other documentation clearly evidencing that the Badu SwimJet System(s) was installed and maintained in strict compliance with this Limited Warranty and that the claim was timely submitted within the Limited Warranty Period; and/or
- (e) Buyer’s failure to comply with the conditions and contingencies set forth in paragraph 3 below.

3. The Limited Warranty is expressly conditioned and contingent upon Buyer’s strict compliance with each of the following:

- (a) Installation of the Badu SwimJet System(s) by an experienced and qualified pool industry professional and a licensed electrician who is licensed within the jurisdiction in which the Badu SwimJet System(s) is installed and will be used; and
- (b) Buyer’s operation and maintenance of the Badu SwimJet System(s) in strict accordance with Speck Pumps-Pool Products, Inc.’s printed operator/maintenance manuals delivered with the Badu SwimJet System(s).

**4. DISCLAIMER: THE LIMITED WARRANTY IS THE ONLY WARRANTY MADE AND IS IN LIEU OF ALL OTHER WARRANTIES, AND ANY AND ALL IMPLIED WARRANTY OR CONDITION OF MERCHANTABILITY, THE IMPLIED WARRANTY AGAINST INFRINGEMENT, AND THE IMPLIED WARRANTY OR CONDITION OF FITNESS FOR A PARTICULAR PURPOSE ARE EXPRESSLY LIMITED IN THEIR SCOPE AND DURATION TO THE ONE YEAR TERM OF THE LIMITED WARRANTY SET FORTH HEREIN. SOME STATES DO NOT ALLOW LIMITATIONS ON HOW LONG AN IMPLIED WARRANTY LASTS, SO THE ABOVE LIMITATION MAY NOT APPLY TO THE BUYER.**

---

## Limited Warranty - continued

---

5. TO THE FULLEST EXTENT PERMITTED BY LAW, IN NO EVENT SHALL SPECK PUMPS-POOL PRODUCTS, INC. OR ITS OFFICERS, DIRECTORS, EMPLOYEES, SHAREHOLDERS, AGENTS, OR REPRESENTATIVES BE LIABLE FOR ANY SPECIAL, INDIRECT, INCIDENTAL, EXEMPLARY OR CONSEQUENTIAL DAMAGES OR LOSS, INCLUDING TIME, MONEY, GOODWILL, AND LOST PROFITS IN ANY WAY WHICH MAY ARISE HEREUNDER OR FROM THE USE OF OR INABILITY TO USE THE BADU SWIMJET SYSTEM(S) OR THE PERFORMANCE OR NONPERFORMANCE OF ANY OBLIGATION UNDER THIS LIMITED WARRANTY. THIS PARAGRAPH, THE WARRANTY DISCLAIMERS IN PARAGRAPH 4 ABOVE, AND THE SOLE AND EXCLUSIVE REMEDY SET FORTH IN PARAGRAPH 1 ABOVE SHALL APPLY EVEN IF SPECK PUMPS-POOL PRODUCTS, INC. HAS BEEN NOTIFIED OF THE POSSIBILITY OR LIKELIHOOD OF SUCH DAMAGES OCCURRING, WHETHER SUCH LIABILITY IS BASED ON CONTRACT, TORT, NEGLIGENCE, STRICT LIABILITY, PRODUCTS LIABILITY OR OTHERWISE, AND EVEN IF ANY REMEDY STATED HEREIN FAILS OF ITS ESSENTIAL PURPOSE. SOME STATES DO NOT ALLOW THE EXCLUSION OR LIMITATION OF SPECIAL, INDIRECT, INCIDENTAL, EXEMPLARY OR CONSEQUENTIAL DAMAGES OR LOSS, SO THE ABOVE EXCLUSIONS AND LIMITATIONS MAY NOT APPLY.

6. This Limited Warranty gives the Buyer specific legal rights, and the Buyer may also have other rights, which vary from state to state.

7. A return merchandise authorization ("RMA") must be obtained from Speck Pumps-Pool Products, Inc. before returning any product. Products returned without an RMA will be refused and returned, unopened, to the Buyer. All returned products are to be sent freight prepaid and insured for Buyer's protection to the manufacturer at 8125 Bayberry Road, Jacksonville, Florida 32256 USA. Under no condition will products be accepted after the expiration of the Limited Warranty Period. Speck Pumps-Pool Products, Inc. shall not bear any costs or risks incurred by Buyer in shipping a defective Badu SwimJet System(s) to Speck Pumps-Pool Products, Inc. or in shipping a repaired or replaced Badu SwimJet System(s) to Buyer.



